

DATA SHEET

SURFACE-MOUNT CERAMIC MULTILAYER CAPACITORS

General purpose & High capacitance

Class 2, X7R

6.3 V TO 50 V

100 pF to 22 μ F

RoHS compliant



SCOPE

This specification describes X7R series chip capacitors with lead-free terminations.

APPLICATIONS

- PCs, Hard disk, Game PCs
- DVDs, Camcorders
- Mobile phones
- Data processing

FEATURES

- Supplied in tape on reel
- Nickel-barrier end termination
- RoHS compliant
- Halogen Free compliant

ORDERING INFORMATION-GLOBAL PART NUMBER, PHYCOMP

CTC & I2NC

All part numbers are identified by the series, size, tolerance, TC material, packing style, voltage, process code, termination and capacitance value. Please note that 12 digits ordering code will expire at the end of 2010.

YAGEO BRAND ordering code

GLOBAL PART NUMBER (PREFERRED)

CC xxxx x x **X7R** x **BB** xxx
 (1) (2) (3) (4) (5)

(1) SIZE – INCH BASED (METRIC)

- 0201 (0603)
- 0402 (1005)
- 0603 (1608)
- 0805 (2012)
- 1206 (3216)
- 1210 (3225)
- 1812 (4532)

(2) TOLERANCE

- J = ±5% ⁽¹⁾
- K = ±10%
- M = ±20%

(3) PACKING STYLE

- R = Paper taping reel; Reel 7 inch
- K = Blister taping reel; Reel 7 inch
- P = Paper taping reel; Reel 13 inch
- F = Blister taping reel; Reel 13 inch
- C = Bulk case

(4) RATED VOLTAGE

- 5 = 6.3 V
- 6 = 10 V
- 7 = 16 V
- 8 = 25 V
- 9 = 50 V

(5) CAPACITANCE VALUE

2 significant digits+number of zeros
 The 3rd digit signifies the multiplying factor, and letter R is decimal point
 Example: 103 = 10 × 10³ = 10,000 pF = 10 nF

NOTE

I. Tolerance ±5% doesn't available for full product range, please contact local sales force before order

PHYCOMP BRAND ordering codes

GLOBAL PART NUMBER (preferred), PHYCOMP CTC (for North America) and I2NC (traditional) codes are acceptable to order Phycomp brand products.

GLOBAL PART NUMBER (PREFERRED)

For detailed information of GLOBAL PART NUMBER and ordering example, please refer to page 2.

I2NC CODE

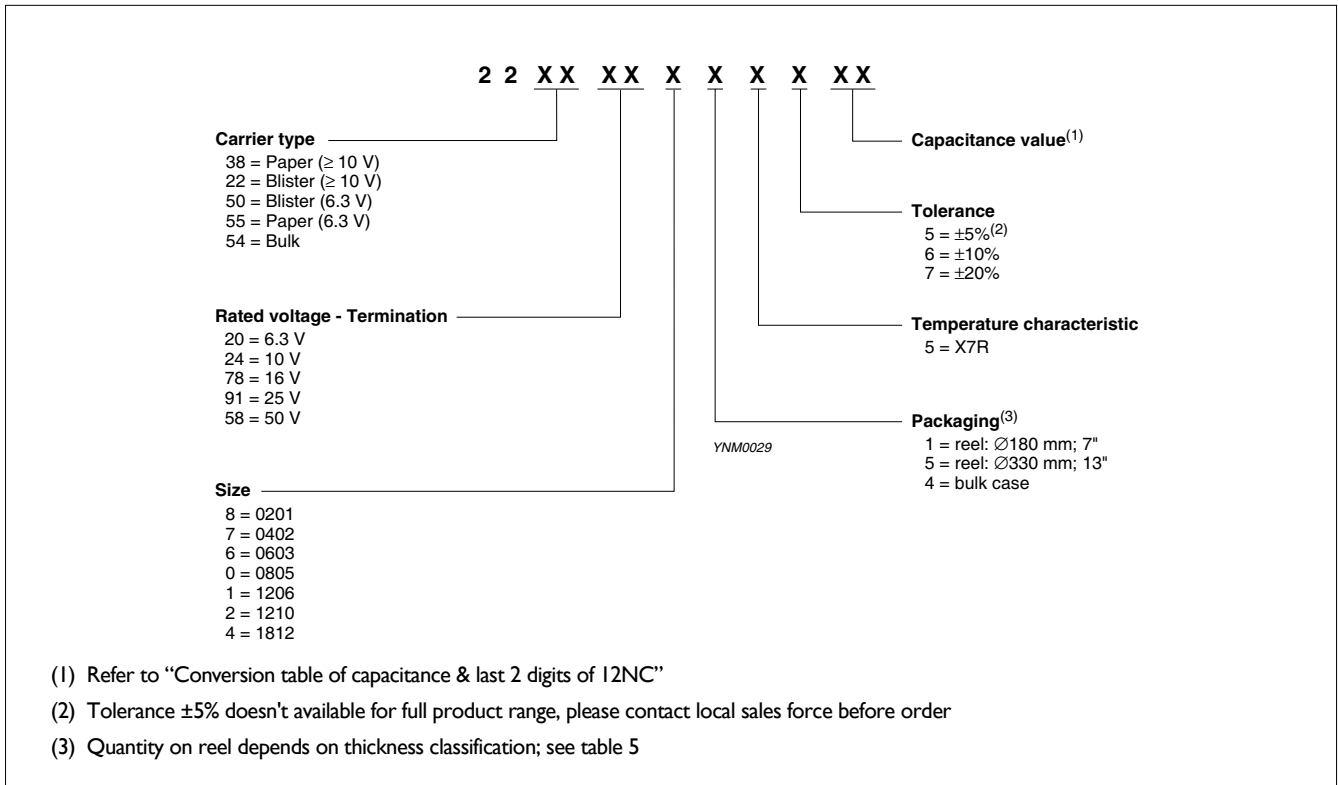

PHYCOMP CTC CODE (FOR NORTH AMERICA)

Example: 02012R102K8B20D

| 0201 | 2R | 102 | K | 8 | B | 2 | 0 | D |
|-----------|-------------|---------------------|------------------------|-----------|-------------|---------------|----------------|------------------|
| Size code | Temp. Char. | Capacitance in pF | Tolerance | Voltage | Termination | Packing | Marking | Range identifier |
| 0201 | 2R = X7R | 101 = 100 pF; | J = ±5% ⁽¹⁾ | 5 = 6.3 V | B = NiSn | 2 = 180 mm / | 0 = no marking | D = Class 2 MLCC |
| 0402 | | the third digit | K = ±10% | 6 = 10 V | | 7" paper | | |
| 0603 | | signifies the | M = ±20% | 7 = 16 V | | 3 = 330 mm | | |
| 0805 | | multiplying factor: | | 8 = 25 V | | 13" paper | | |
| 1206 | | 0 = × 1 | | 9 = 50 V | | B = 180 mm | | |
| 1210 | | 1 = × 10 | | | | 7" blister | | |
| 1812 | | 2 = × 100 | | | | F = 330 mm | | |
| | | 3 = × 1,000 | | | | 13" blister | | |
| | | | | | | P = Bulk case | | |

NOTE

I. Tolerance ±5% doesn't available for full product range, please contact local sales force before order

CONSTRUCTION

The capacitor consists of a rectangular block of ceramic dielectric in which a number of interleaved metal electrodes are contained. This structure gives rise to a high capacitance per unit volume.

The inner electrodes are connected to the two end terminations and finally covered with a layer of plated tin (NiSn). The terminations are lead-free. A cross section of the structure is shown in Fig. 1.

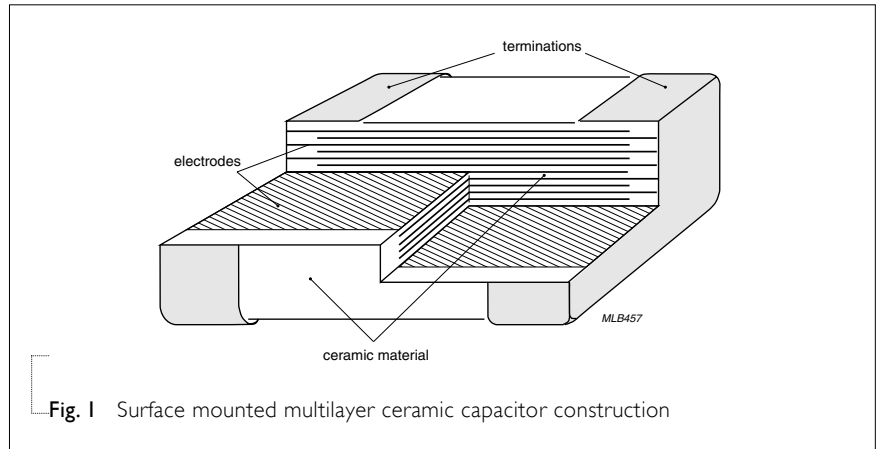

Fig. 1 Surface mounted multilayer ceramic capacitor construction

DIMENSION

Table I For outlines see fig. 2

| TYPE | L ₁ (mm) | W (mm) | T (MM) | L ₂ / L ₃ (mm) | | L ₄ (mm) |
|------|--------------------------|---------------------------|--------------------------|--------------------------------------|------|---------------------|
| | | | | min. | max. | min. |
| 0201 | 0.6 ±0.03 | 0.3 ±0.03 | Refer to table 2 to 4 | 0.10 | 0.20 | 0.20 |
| 0402 | 1.0 ±0.05 | 0.5 ±0.05 | | 0.20 | 0.30 | .40 |
| 0603 | 1.6 ±0.10 | 0.8 ±0.10 | | 0.20 | 0.60 | 0.40 |
| 0805 | 2.0 ±0.10 ⁽¹⁾ | 1.25 ±0.10 ⁽¹⁾ | | 0.25 | 0.75 | 0.55 |
| | 2.0 ±0.20 ⁽²⁾ | 1.25 ±0.20 ⁽²⁾ | | | | |
| 1206 | 3.2 ±0.15 ⁽¹⁾ | 1.6 ±0.15 ⁽¹⁾ | | 0.25 | 0.75 | 1.40 |
| | 3.2 ±0.20 ⁽²⁾ | 1.6 ±0.20 ⁽²⁾ | | | | |
| 1210 | 3.2 ±0.20 | 2.5 ±0.20 | | 0.25 | 0.75 | 1.40 |
| 1812 | 4.5 ±0.20 ⁽¹⁾ | 3.2 ±0.20 | | 0.25 | 0.75 | 2.20 |
| | 4.5 ±0.40 ⁽²⁾ | | | | | |

NOTE

- 1. Dimension for size 0805 to 1812, C < 1 μF
- 2. Dimension for size 0805 to 1812, C ≥ 1 μF

OUTLINES

For dimension see Table I

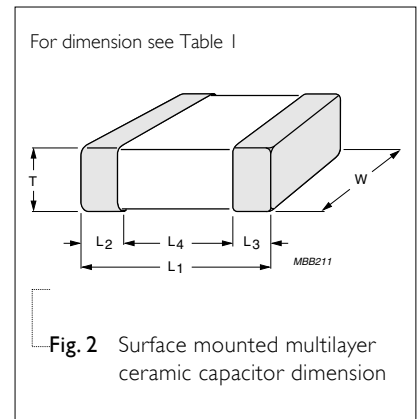

Fig. 2 Surface mounted multilayer ceramic capacitor dimension

CAPACITANCE RANGE & THICKNESS FOR X7R

Table 2 Sizes from 0201 to 0402

| CAP. | Last 2 digits of 12NC | 0201 | | | | 0402 | | | | |
|--------|-----------------------|----------|----------|------|----------|----------|----------|----------|----------|----------|
| | | 6.3 V | 10 V | 16 V | 25 V | 6.3 V | 10 V | 16 V | 25 V | 50 V |
| 100 pF | 09 | | | | | | | | | |
| 150 pF | 12 | | | | | | | | | |
| 220 pF | 14 | | | | | | | | | |
| 330 pF | 16 | | | | 0.3±0.03 | | | | | |
| 470 pF | 18 | | | | | | | | | |
| 680 pF | 21 | | | | | | | | | |
| 1.0 nF | 23 | | | | | | | | | 0.5±0.05 |
| 1.5 nF | 25 | | | | | | | | 0.5±0.05 | |
| 2.2 nF | 27 | | | | | | | | | |
| 3.3 nF | 29 | | | | 0.3±0.03 | | | 0.5±0.05 | | |
| 4.7 nF | 32 | 0.3±0.03 | 0.3±0.03 | | | | | | | |
| 6.8 nF | 34 | | | | | | | | | |
| 10 nF | 36 | | | | | | | | | |
| 15 nF | 38 | | | | | | | | | |
| 22 nF | 41 | | | | | | | | | |
| 33 nF | 43 | | | | | | | | | |
| 47 nF | 45 | | | | | 0.5±0.05 | 0.5±0.05 | | | |
| 68 nF | 47 | | | | | | | | | |
| 100 nF | 49 | | | | | | | | | |
| 150 nF | 52 | | | | | | | | | |
| 220 nF | 54 | | | | | | | | | |
| 330 nF | 56 | | | | | | | | | |
| 470 nF | 58 | | | | | | | | | |
| 680 nF | 61 | | | | | | | | | |
| 1.0 μF | 63 | | | | | | | | | |
| 2.2 μF | 67 | | | | | | | | | |
| 4.7 μF | 72 | | | | | | | | | |
| 10 μF | 76 | | | | | | | | | |
| 22 μF | 81 | | | | | | | | | |

NOTE

1. Values in shaded cells indicate thickness class in mm
2. Capacitance value of non E-6 series is on request
3. For product with 5% tolerance, please contact local sales force before order

CAPACITANCE RANGE & THICKNESS FOR X7R

Table 3 Sizes from 0603 to 0805

| CAP. | Last 2 digits of 12NC | 0603 | | | | | 0805 | | | | |
|--------|-----------------------|---------|---------|---------|---------|---------|----------|----------|----------|----------|----------|
| | | 6.3 V | 10 V | 16 V | 25 V | 50 V | 6.3 V | 10 V | 16 V | 25 V | 50 V |
| 100 pF | 09 | | | | | | | | | | |
| 150 pF | 12 | | | | | | | | | | |
| 220 pF | 14 | | | | | | | | | | |
| 330 pF | 16 | | | | | | | | | | |
| 470 pF | 18 | | | | | | | | | | |
| 680 pF | 21 | | | | | | | | | | |
| 1.0 nF | 23 | | | | | | | | | | |
| 1.5 nF | 25 | | | | | | | | | | |
| 2.2 nF | 27 | | | | | | | | | | |
| 3.3 nF | 29 | | | | | | | | | | |
| 4.7 nF | 32 | | | | 0.8±0.1 | | | | | | |
| 6.8 nF | 34 | | 0.8±0.1 | 0.8±0.1 | | 0.8±0.1 | | | | | |
| 10 nF | 36 | | | | | | | | | | |
| 15 nF | 38 | | | | | | | | | | |
| 22 nF | 41 | | | | | | | | | | |
| 33 nF | 43 | | | | | | | | | | |
| 47 nF | 45 | | | | | | | | | | |
| 68 nF | 47 | | | | | | | | 0.6±0.1 | | |
| 100 nF | 49 | | | | | | | | | 0.85±0.1 | |
| 150 nF | 52 | | | | | | | | 0.85±0.1 | | |
| 220 nF | 54 | 0.8±0.1 | | | | | | | | | 1.25±0.2 |
| 330 nF | 56 | | | | | | | | | | |
| 470 nF | 58 | | | | | | | | | | |
| 680 nF | 61 | | | | | | 1.25±0.2 | 1.25±0.2 | 1.25±0.2 | 1.25±0.2 | |
| 1.0 µF | 63 | 0.8±0.1 | 0.8±0.1 | 0.8±0.1 | | | | | | | |
| 2.2 µF | 67 | | | | | | | | | | |
| 4.7 µF | 72 | | | | | | | | | | |
| 10 µF | 76 | | | | | | | | | | |
| 22 µF | 81 | | | | | | | | | | |

NOTE

1. Values in shaded cells indicate thickness class in mm
2. Capacitance value of non E-6 series is on request
3. For product with 5% tolerance, please contact local sales force before order

CAPACITANCE RANGE & THICKNESS FOR X7R

Table 4 Sizes from 1206 to 1812

| CAP. | Last 2 digits of 12NC | 1206 | | | | | 1210 | | | | | 1812 | |
|--------|-----------------------|----------|----------|----------|----------|----------|----------|---------|----------|----------|----------|------|--|
| | | 6.3 V | 10 V | 16 V | 25 V | 50 V | 10 V | 16 V | 25 V | 50 V | 50 V | | |
| 100 pF | 09 | | | | | | | | | | | | |
| 150 pF | 12 | | | | | | | | | | | | |
| 220 pF | 14 | | | | | | | | | | | | |
| 330 pF | 16 | | | | | | | | | | | | |
| 470 pF | 18 | | | | | | | | | | | | |
| 680 pF | 21 | | | | | | | | | | | | |
| 1.0 nF | 23 | | | | | | | | | | | | |
| 1.5 nF | 25 | | | | | | | | | | | | |
| 2.2 nF | 27 | | | | | | | | | | | | |
| 3.3 nF | 29 | | | | | | | | | | | | |
| 4.7 nF | 32 | | | | | 0.85±0.1 | | | | | | | |
| 6.8 nF | 34 | | | | 0.85±0.1 | | | | | | | | |
| 10 nF | 36 | | | | | | | | | | | | |
| 15 nF | 38 | | | | | | | | 0.85±0.1 | | 0.85±0.1 | | |
| 22 nF | 41 | | | | | | | | | | | | |
| 33 nF | 43 | | | | | | | | | | | | |
| 47 nF | 45 | | | | | | | | | | | | |
| 68 nF | 47 | | | | | | | | | | | | |
| 100 nF | 49 | | | | | | | | | | | | |
| 150 nF | 52 | | | | | | 1.15±0.1 | | | | | | |
| 220 nF | 54 | | | | | | | | | 1.15±0.1 | | | |
| 330 nF | 56 | | | 0.85±0.1 | 0.85±0.1 | 0.85±0.1 | | | 0.85±0.1 | | 1.15±0.1 | | |
| 470 nF | 58 | | | 0.85±0.1 | 0.85±0.1 | 1.0±0.1 | | | | 1.15±0.1 | 1.6±0.2 | | |
| 680 nF | 61 | | | | | | | | | | | | |
| 1.0 µF | 63 | 1.15±0.1 | 1.15±0.1 | 1.15±0.1 | 1.15±0.1 | 1.6±0.2 | | | 1.25±0.2 | 1.25±0.2 | 1.6±0.2 | | |
| 2.2 µF | 67 | | | | | | | | | | | | |
| 4.7 µF | 72 | | | | 1.6±0.2 | | | | 1.9±0.2 | | | | |
| 10 µF | 76 | 1.6±0.2 | 1.6±0.2 | 1.6±0.2 | | | 1.9±0.2 | 1.9±0.2 | | | | | |
| 22 µF | 81 | | | | | | 2.5±0.2 | | | | | | |

NOTE

1. Values in shaded cells indicate thickness class in mm
2. Capacitance value of non E-6 series is on request
3. For product with 5% tolerance, please contact local sales force before order

THICKNESS CLASSES AND PACKING QUANTITY

Table 5

| SIZE CODE | THICKNESS CLASSIFICATION | TAPE WIDTH QUANTITY PER REEL | Ø180 MM / 7 INCH | | Ø330 MM / 13 INCH | | QUANTITY PER BULK CASE |
|-------------|--------------------------|---------------------------------|------------------|----------------|-------------------|---------|------------------------|
| | | | Paper | Blister | Paper | Blister | |
| 0201 | 0.3 ±0.03 mm | 8 mm | 15,000 | --- | 50,000 | --- | --- |
| 0402 | 0.5 ±0.05 mm | 8 mm | 10,000 | --- | 50,000 | --- | 50,000 |
| 0603 | 0.8 ±0.1 mm | 8 mm | 4,000 | --- | 15,000 | --- | 15,000 |
| 0805 | 0.6 ±0.1 mm | 8 mm | 4,000 | --- | 20,000 | --- | 10,000 |
| | 0.85 ±0.1 mm | 8 mm | 4,000 | --- | 15,000 | --- | 8,000 |
| | 1.25 ±0.2 mm | 8 mm | --- | 3,000 | --- | 10,000 | 5,000 |
| 1206 | 0.6 ±0.1 mm | 8 mm | 4,000 | --- | 20,000 | --- | --- |
| | 0.85 ±0.1 mm | 8 mm | 4,000 | --- | 15,000 | --- | --- |
| | 1.00 / 1.15 ±0.1 mm | 8 mm | --- | 3,000 | --- | 10,000 | --- |
| | 1.25 ±0.2 mm | 8 mm | --- | 3,000 | --- | 10,000 | --- |
| | 1.6 ±0.15 mm | 8 mm | --- | 2,500 | --- | 10,000 | --- |
| 1210 | 1.6 ±0.2 mm | 8 mm | --- | 2,000 | --- | 10,000 | --- |
| | 0.6 / 0.7 ±0.1 mm | 8 mm | --- | 4,000 | --- | 15,000 | --- |
| | 0.85 ±0.1 mm | 8 mm | --- | 4,000 | --- | 10,000 | --- |
| | 1.15 ±0.1 mm | 8 mm | --- | 3,000 | --- | 10,000 | --- |
| | 1.15 ±0.15 mm | 8 mm | --- | 3,000 | --- | 10,000 | --- |
| | 1.25 ±0.2 mm | 8 mm | --- | 3,000 | --- | --- | --- |
| | 1.5 ±0.1 mm | 8 mm | --- | 2,000 | --- | --- | --- |
| | 1.6 / 1.9 ±0.2 mm | 8 mm | --- | 2,000 | --- | --- | --- |
| 1808 | 2.0 ±0.2 mm | 8 mm | --- | 2,000 1,000 | --- | --- | --- |
| | 2.5 ±0.2 mm | 8 mm | --- | 1,000 500 | --- | --- | --- |
| | 1.15 ±0.15 mm | 12 mm | --- | 3,000 | --- | --- | --- |
| | 1.25 ±0.2 mm | 12 mm | --- | 3,000 | --- | --- | --- |
| | 1.35 ±0.15 mm | 12 mm | --- | 2,000 | --- | --- | --- |
| | 1.5 ±0.1 mm | 12 mm | --- | 2,000 | --- | --- | --- |
| 1812 | 1.6 ±0.2 mm | 12 mm | --- | 2,000 | --- | --- | --- |
| | 2.0 ±0.2 mm | 12 mm | --- | 2,000 | --- | --- | --- |
| | 0.6 / 0.85 ±0.1 mm | 12 mm | --- | 2,000 | --- | --- | --- |
| | 1.15 ±0.1 mm | 12 mm | --- | 1,500 | --- | --- | --- |
| | 1.15 ±0.15 mm | 12 mm | --- | 1,500 | --- | --- | --- |
| | 1.35 ±0.15 mm | 12 mm | --- | 1,000 | --- | --- | --- |
| | 1.5 ±0.1 mm | 12 mm | --- | 1,000 | --- | --- | --- |
| | 1.6 ±0.2 mm | 12 mm | --- | 1,000 | --- | --- | --- |
| 2.0 ±0.2 mm | 12 mm | --- | 1,000 | --- | --- | --- | |
| 2.5 ±0.2 mm | 12 mm | --- | 500 | 50,000 | --- | --- | |

ELECTRICAL CHARACTERISTICS

X7R DIELECTRIC CAPACITORS; NISN TERMINATIONS

Unless otherwise stated all electrical values apply at an ambient temperature of 20±1 °C, an atmospheric pressure of 86 to 106 kPa, and a relative humidity of 63 to 67%.

Table 6

| DESCRIPTION | VALUE |
|---|---|
| Capacitance range | 100 pF to 22 µF |
| Capacitance tolerance | ±5%, ±10%, ±20% |
| Dissipation factor (D.F.) | |
| ≤ 10 V | ≤ 5% |
| Exception: 0201 ≥ 12 nF; 0805 ≥ 10 µF | ≤ 10% |
| 16 V | ≤ 3.5% |
| Exception: 0201 ≥ 1.5 nF; 0402 ≥ 27 nF; 0603 ≥ 220 nF; 0805 ≥ 680 nF; 1206 ≥ 2.2 µF; 1210 ≥ 10 µF | ≤ 5% |
| 25 V | ≤ 2.5% |
| Exception: 0402 ≥ 10 nF; 0603 ≥ 47 nF; 0805 ≥ 220 nF; 1206 ≥ 1 µF; 1210 ≥ 4.7 µF | ≤ 3.5% |
| 0201 ≥ 560 pF; 0603 ≥ 1 µF; | ≤ 5% |
| 0805 ≥ 680 nF; 1206 ≥ 2.2 µF; 1210 ≥ 10 µF | |
| ≥ 50 V | ≤ 2.5% |
| Exception: 0201 ≥ 47 pF; 1206 ≥ 1 µF | ≤ 3.5% |
| 0603 ≥ 47 nF | ≤ 3.0% |
| Insulation resistance after 1 minute at U _r (DC) | R _{ins} ≥ 10 GΩ or R _{ins} × C _r ≥ 500 seconds whichever is less |
| Maximum capacitance change as a function of temperature (temperature characteristic/coefficient): | ±15% |
| Operating temperature range: | -55 °C to +125 °C |

NOTE

Capacitance tolerance ±5% doesn't available for full product range, please contact local sales force before order

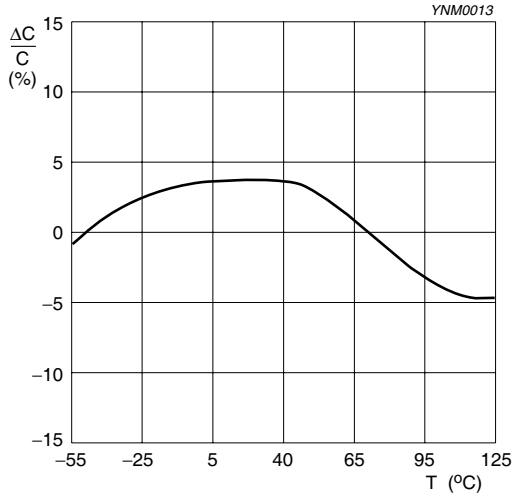

Fig. 3 Typical capacitance change as a function of temperature

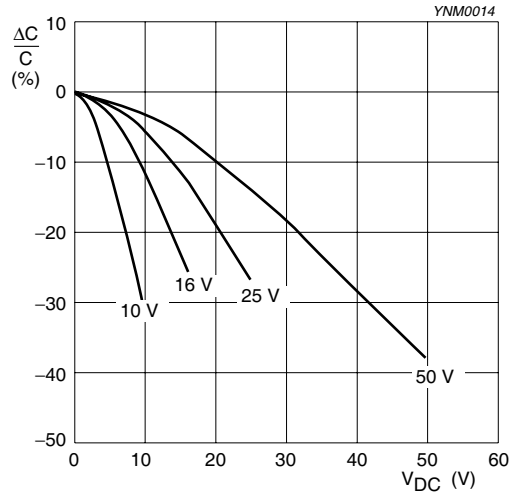

Fig. 4 Typical capacitance change with respect to the capacitance at 1 V as a function of DC voltage at 20 °C

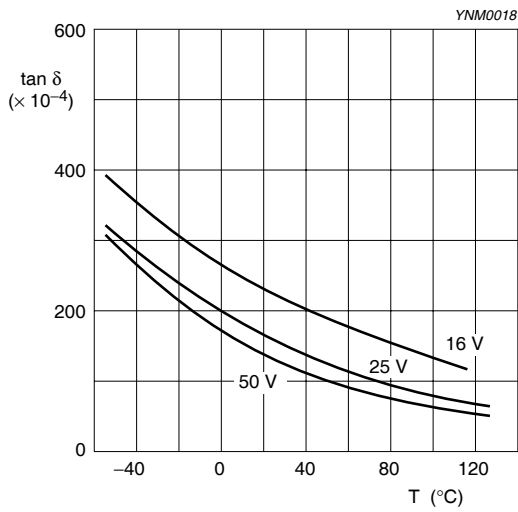

Fig. 5 Typical tan δ as a function of temperature

SOLDERING RECOMMENDATION

Table 7

| SOLDERING METHOD | SIZE | | | | |
|------------------|----------|----------|----------|----------|-------------|
| | 0402 | 0603 | 0805 | 1206 | ≥ 1210 |
| Reflow | ≥ 0.1 μF | ≥ 1.0 μF | ≥ 2.2 μF | ≥ 4.7 μF | Reflow only |
| Reflow/Wave | < 0.1 μF | < 1.0 μF | < 2.2 μF | < 4.7 μF | --- |

TESTS AND REQUIREMENTS

Table 8 Test procedures and requirements

| TEST | TEST METHOD | PROCEDURE | REQUIREMENTS |
|---------------------------------------|-----------------|---|---|
| Mounting | IEC 60384-21/22 | 4.3 The capacitors may be mounted on printed-circuit boards or ceramic substrates | No visible damage |
| Visual inspection and dimension check | 4.4 | Any applicable method using × 10 magnification | In accordance with specification |
| Capacitance | 4.5.1 | Class 2: f = 1 KHz for C ≤ 10 μF, measuring at voltage 1 V _{rms} at 20 °C f = 120 Hz for C > 10 μF, measuring at voltage 0.5 V _{rms} at 20 °C | Within specified tolerance |
| Dissipation factor (D.F.) | 4.5.2 | Class 2: f = 1 KHz for C ≤ 10 μF, measuring at voltage 1 V _{rms} at 20 °C f = 120 Hz for C > 10 μF, measuring at voltage 0.5 V _{rms} at 20 °C | In accordance with specification |
| Insulation resistance | 4.5.3 | At U _r (DC) for 1 minute | In accordance with specification |
| Temperature characteristic | 4.6 | Class 2: Between minimum and maximum temperature X7R: -55 °C to +125 °C Normal Temperature: 20 °C | <General purpose series> ΔC/C Class 2: X7R: ±15% <High Capacitance series> ΔC/C Class 2: X7R: ±15% |

| TEST | TEST METHOD | PROCEDURE | REQUIREMENTS |
|--------------------------------------|---------------------|---|---|
| Adhesion | IEC 60384-21/22 4.7 | A force applied for 10 seconds to the line joining the terminations and in a plane parallel to the substrate | Force size ≥ 0603: 5N size = 0402: 2.5N size = 0201: 1N |
| Bond strength of plating on end face | 4.8 | Mounting in accordance with IEC 60384-22 paragraph 4.3 Conditions: bending 1 mm at a rate of 1 mm/s, radius jig 340 mm | No visible damage <General purpose series> ΔC/C Class2: X7R: ±10% <High Capacitance series> ΔC/C Class2: X7R: ±10% |
| Resistance to soldering heat | 4.9 | Precondition: 150 +0/-10 °C for 1 hour, then keep for 24 ±1 hours at room temperature Preheating: for size ≤ 1206: 120 °C to 150 °C for 1 minute Preheating: for size >1206: 100 °C to 120 °C for 1 minute and 170 °C to 200 °C for 1 minute Solder bath temperature: 260 ±5 °C Dipping time: 10 ±0.5 seconds Recovery time: 24 ±2 hours | Dissolution of the end face plating shall not exceed 25% of the length of the edge concerned <General purpose series> ΔC/C Class2: X7R: ±10% <High Capacitance series> ΔC/C Class2: X7R: ±10% D.F. within initial specified value R _{ins} within initial specified value |

| TEST | TEST METHOD | PROCEDURE | REQUIREMENTS |
|-----------------------------|-----------------|--|---|
| Solderability | IEC 60384-21/22 | 4.10 Preheated the temperature of 80 °C to 140 °C and maintained for 30 seconds to 60 seconds. | The solder should cover over 95% of the critical area of each termination |
| | | <p>Test conditions for lead containing solder alloy</p> <p>Temperature: 235 ±5 °C</p> <p>Dipping time: 2 ±0.2 seconds</p> <p>Depth of immersion: 10 mm</p> <p>Alloy Composition: 60/40 Sn/Pb</p> <p>Number of immersions: 1</p> <p>Test conditions for leadfree containing solder alloy</p> <p>Temperature: 245 ±5 °C</p> <p>Dipping time: 3 ±0.3 seconds</p> <p>Depth of immersion: 10 mm</p> <p>Alloy Composition: SAC305</p> <p>Number of immersions: 1</p> | |
| Rapid change of temperature | 4.11 | <p>Preconditioning:</p> <p>150 +0/-10 °C for 1 hour, then keep for 24 ±1 hours at room temperature</p> <p>5 cycles with following detail:</p> <p>30 minutes at lower category temperature</p> <p>30 minutes at upper category temperature</p> <p>Recovery time 24 ±2 hours</p> | <p>No visual damage</p> <hr/> <p><General purpose series></p> <p>ΔC/C</p> <p>Class2:</p> <p>X7R: ±15%</p> <p><High Capacitance series></p> <p>ΔC/C</p> <p>Class2:</p> <p>X7R: ±15%</p> <hr/> <p>D.F. meet initial specified value</p> <p>R₁₇₅ meet initial specified value</p> |

| TEST | TEST METHOD | PROCEDURE | REQUIREMENTS |
|---------------------------|----------------------|---|--|
| Damp heat with U_r load | IEC 60384-21/22 4.13 | <ol style="list-style-type: none"> 1. Preconditioning, class 2 only: 150 +0/-10 °C /1 hour, then keep for 24 ±1 hour at room temp 2. Initial measure: Spec: refer initial spec C, D, IR 3. Damp heat test: 500 ±12 hours at 40 ±2 °C; 90 to 95% R.H. 1.0 U_r applied 4. Recovery: Class 2: 24 ±2 hours 5. Final measure: C, D, IR <p>P.S. If the capacitance value is less than the minimum value permitted, then after the other measurements have been made the capacitor shall be precondition according to "IEC 60384 4.1" and then the requirement shall be met.</p> | <p>No visual damage after recovery</p> <hr/> <p><General purpose series> $\Delta C/C$ Class2: X7R: ±15% D.F. Class2: X7R: ≤ 16V: ≤ 7% ≥ 25V: ≤ 5%</p> <p>R_{ins} Class2: X7R: ≥ 500 MΩ or $R_{ins} \times C_r \geq 25s$ whichever is less</p> <p><High Capacitance series> $\Delta C/C$ Class2: X7R: ±20% D.F. Class2: X7R: 2 × initial value max</p> <p>R_{ins} Class2: X7R: 500 MΩ or $R_{ins} \times C_r \geq 25s$ whichever is less</p> |

| TEST | TEST METHOD | PROCEDURE | REQUIREMENTS |
|---------------|-----------------------|--|--|
| Endurance | IEC 60384- 21/22 4.14 | <ol style="list-style-type: none"> Preconditioning, class 2 only: 150 +0/-10 °C /1 hour, then keep for 24 ±1 hour at room temp Initial measure: Spec: refer initial spec C, D, IR Endurance test: Temperature: X7R: 125 °C Specified stress voltage applied for 1,000 hours: Applied 2.0 × U_r for general product. Applied 1.5 × U_r for high cap. product. Recovery time: 24 ±2 hours Final measure: C, D, IR <p>P.S. If the capacitance value is less than the minimum value permitted, then after the other measurements have been made the capacitor shall be precondition according to "IEC 60384 4.1" and then the requirement shall be met.</p> | <p>No visual damage</p> <hr/> <p><General purpose series> ΔC/C Class2: X7R: ±15% D.F. Class2: X7R: ≤ 16V: ≤ 7% ≥ 25V: ≤ 5% R_{ins} Class2: X7R: ≥ 1,000 MΩ or R_{ins} × C_r ≥ 50s whichever is less</p> <p><High Capacitance series> ΔC/C Class 2: X7R: ±20% D.F. Class 2: X7R: 2 × initial value max R_{ins} Class 2: X7R: 1,000 MΩ or R_{ins} × C_r ≥ 50s whichever is less</p> |
| Voltage proof | IEC 60384- 4.6 I | <p>Specified stress voltage applied for 1 minute</p> <p>U_r ≤ 100 V: series applied 2.5 U_r 100 V < U_r ≤ 200 V series applied (1.5 U_r + 100) 200 V < U_r ≤ 500 V series applied (1.3 U_r + 100) U_r > 500 V: 1.3 U_r I: 7.5 mA</p> | No breakdown or flashover |

REVISION HISTORY

| REVISION | DATE | CHANGE NOTIFICATION | DESCRIPTION |
|-----------|--------------|---------------------|---|
| Version 1 | Apr 24, 2009 | - | - Ordering code updated |
| Version 0 | Apr 15, 2009 | - | <ul style="list-style-type: none"> - New datasheet for general purpose and high capacitance X7R series with RoHS compliant - Replace the "6.3V to 50V" part of pdf files: X7R_10V_9, X7R_16V-to-100V_9, X7R_16-to-500V_9, UP-X5R_X7R_HighCaps_6.3-to-25V_11, UY-X5R_X7R_HighCaps_6.3-to-25V_11 - Combine 0201 from pdf files: UP-NP0X5RX7RY5V_0201_6.3-to-50V_2 and UY-NPOX5RX7RY5V_0201_6.3-to-50V_2 - Define global part number - Description of "Halogen Free compliant" added - Test method and procedure updated |